

INSTALLATION INSTRUCTIONS COMMERCIAL KEY-IN-LEVER

FOR USE ON DOORS 1-3/8"~2" (35mm-51mm) THICK

TOOLS REQUIRED FOR NEW INSTALLATION:

- 1 philips head screwdriver
- 1 2-1/8" (54mm) hole saw
- 1 1" (25.4mm) drill bit
- 1 5/16" (8mm) drill bit
- 1 chisel

TOOLS REQUIRED FOR REPLACEMENT:

- 1 philips head screwdriver

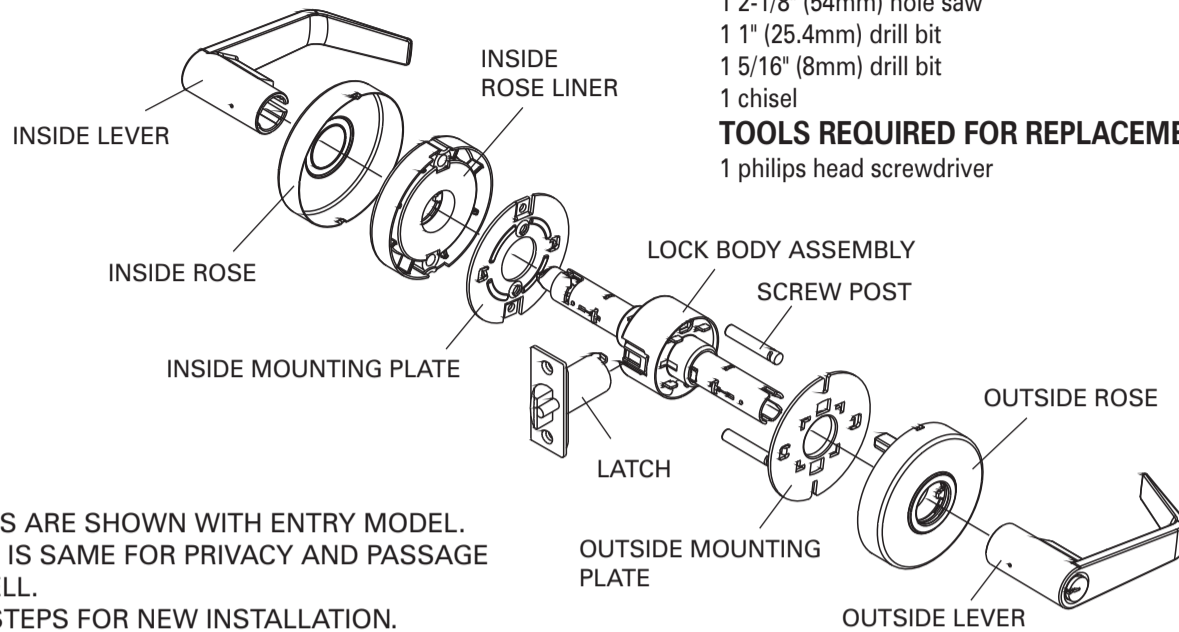

ILLUSTRATIONS ARE SHOWN WITH ENTRY MODEL. INSTALLATION IS SAME FOR PRIVACY AND PASSAGE MODEL AS WELL. FOLLOW ALL STEPS FOR NEW INSTALLATION. FOLLOW STEPS 3C,4C,5,6,7,8,9 FOR REPLACEMENT INSTALLATION AFTER REMOVAL OF OLD LOCK AND LATCH.

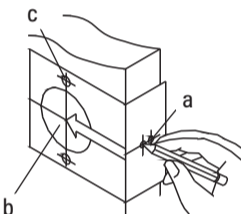
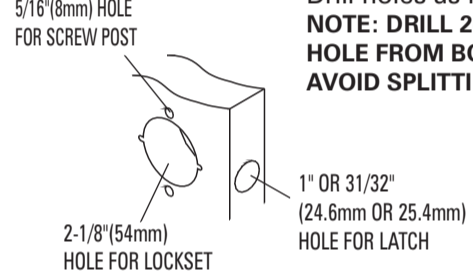
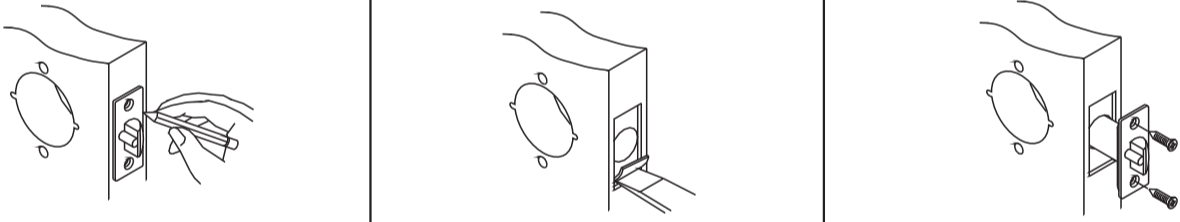
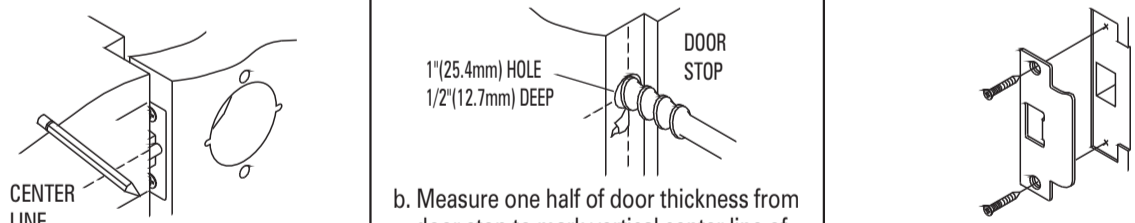
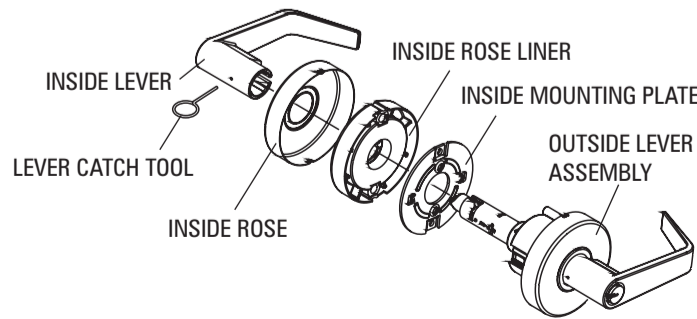
<p>1. MARK DOOR</p>  <p>a. Start 38" from floor and mark center of door edge. b. Select backset 2-3/8" or 2-3/4" and mark hole center on door face. c. Mark two holes for screw post.</p> <p>NOTE: BACKSET ON DOOR FACE MUST BE SAME AS BACKSET OF YOUR LOCK.</p>		<p>2. DRILL HOLES</p>  <p>Drill holes as marked. NOTE: DRILL 2-1/8" (54mm) HOLE FROM BOTH SIDES TO AVOID SPLITTING WOOD.</p>	
<p>3. INSTALL LATCH</p>  <p>a. Insert latch in hole and keep it parallel to door face. Mark outline and remove latch.</p> <p>b. Chisel 1/8" (3mm) deep or until faceplate flush with door edge.</p> <p>c. Insert latch and tighten screws. NOTE: LATCHBOLT BEVEL MUST FACE TO CLOSING DIRECTION.</p>			
<p>4. INSTALL STRIKE</p>  <p>a. Close door to mark horizontal center line of strike.</p> <p>b. Measure one half of door thickness from door stop to mark vertical center line of strike. Drill 1" (25.4mm) hole, 1/2" (12.7mm) deep at intersection of horizontal and vertical center lines.</p> <p>c. Cut out jamb 3/32" (2.4mm) deep or until strike flush with jamb. Tighten screws securely.</p>			
<p>5. REMOVE INSIDE TRIM</p> <p>Use lever catch tool to depress lever catch visible under hole of inside lever shank and slide off inside lever, rose, rose liner and mounting plate.</p> 			

6. INSTALL REMOVABLE THRU-BOLT (SCREW POST)

- a. Disassemble outside mounting plate from outside rose plate.
- b. Make clearance between outside mounting plate and insert the removable thru-bolt (screw post) into the cavities of outside mounting plate.
- c. Continuing the follow up instructions.

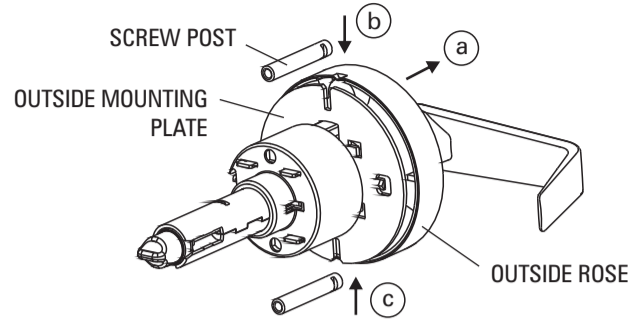

7. ADJUST DOOR THICKNESS

- a. Remove outside mounting plate toward cylindrical case.
- b. Put the catch tool into the allocated position of outside mounting plate as the illustrating bellow.
- c. Rotate outside mounting plate to required door thickness by using a catch tool.

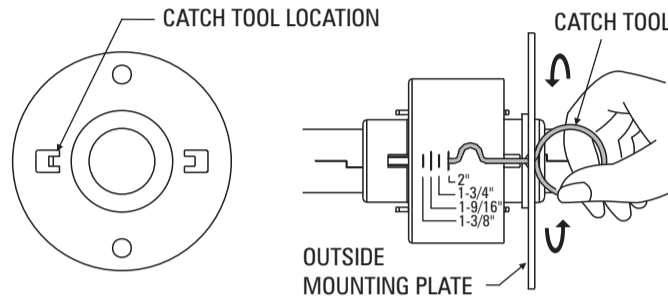

8. INSTALL OUTSIDE LEVER ASSEMBLY

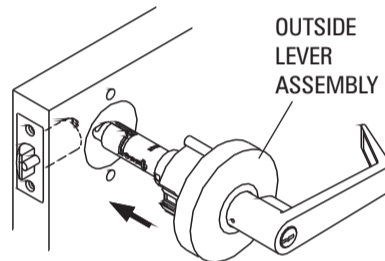
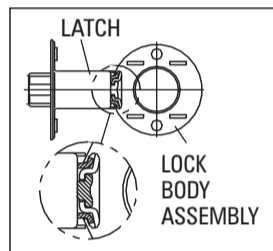

Install outside lever assembly on the door. Make sure tail of latch engaging with retractor correctly as illustration left.

9. INSTALL INSIDE MOUNTING PLATE AND ROSE LINER

- a. Place mounting plate on door face and turn up the lever slightly and tighten screws securely.

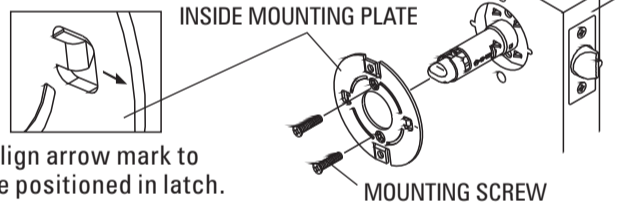

Align arrow mark to be positioned in latch.

10. INSTALL INSIDE ROSE AND LEVER

- a. Press rose onto rose liner. Be sure to fit rose in recess of rose liner.

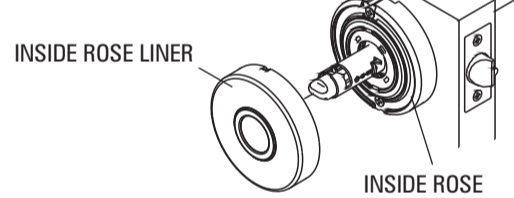

- b. Place rose liner on mounting plate and tighten with screw securely.

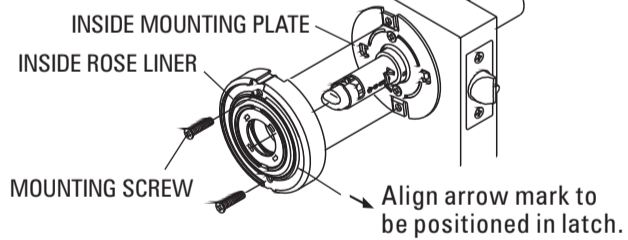

Align arrow mark to be positioned in latch.

- b. Use lever catch to press down catch in the hole and push inside lever all the way in until clicks into catch hole.

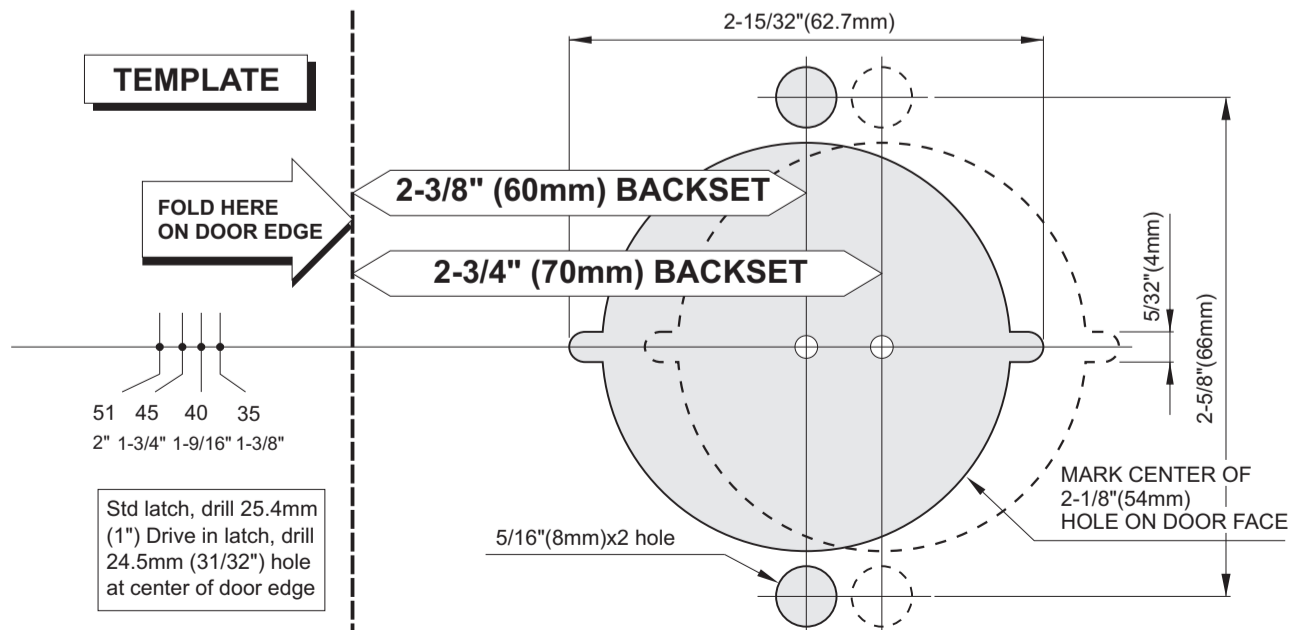
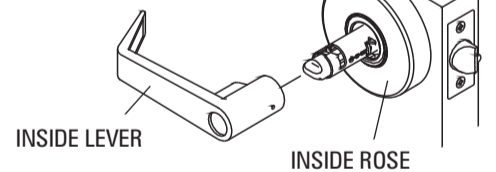

RE-INSTALL INSTRUCTIONS (after re-keying)

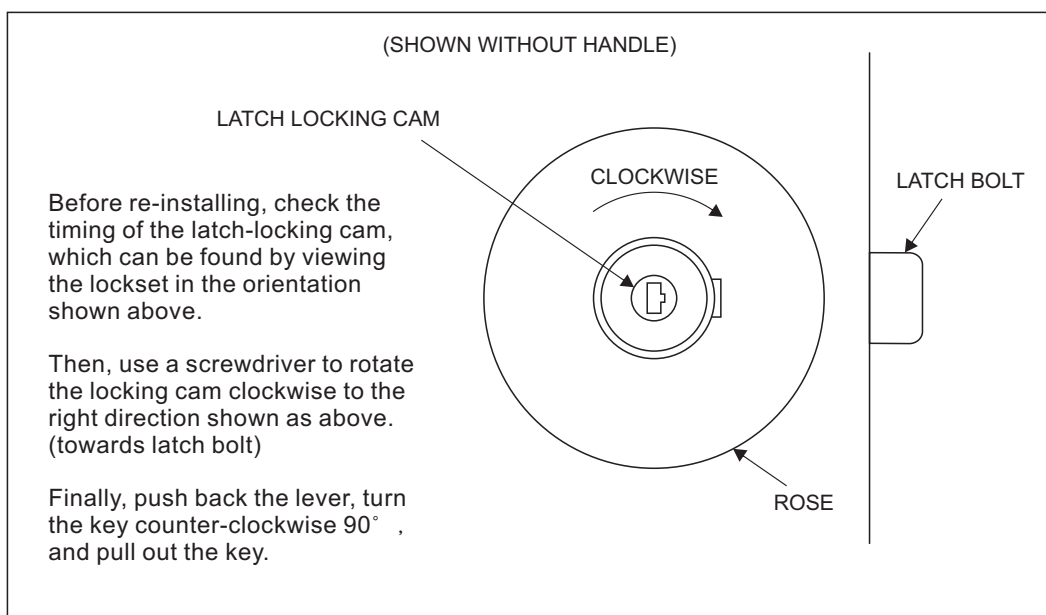

INSTRUCTION FOR INSTALLATION OF DUMMY LEVER (515EV)

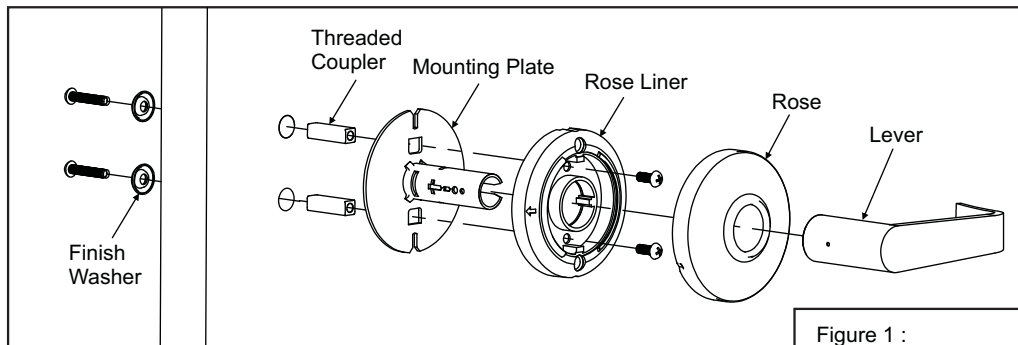

NOTE :
For 1-3/8" (35mm) thick door, use 1" (25.4mm) long machine screws.

For 1-3/4" (45mm) thick door, use 1-3/8" (35mm) long machine screws.

1. Drill (2) 1/2" (12.7mm) diameter holes thru the face of the door.
(for wood doors, drill half way thru both sides of the door to avoid splintering.)
2. Insert mounting plate through rose liner so they sit flush.
3. Tighten rose liner and mounting plate together using (2) 1/2" (12.7mm) long machine screws and (2) threaded couplers. See figure 1.
4. Place newly assembled parts on outside face of the door.
5. Tighten assembly to the door using (2) machine screws and (2) finish washers (machine screws should tighten to the threaded couplers inside drilled holes in the door).
6. Make sure both sides are completely tightened down and then install the rose over the rose liner.
7. Insert lever until it snaps securely in place.

Figure 1 :
When tightened down, coupler will tighten to the rose liner. Coupler must sit in the hole of the mounting plate so that it cannot twist.

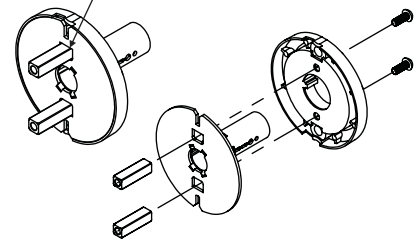

TEMPLATE

Fit here on door edge

BACKSET 2-3/8" (60mm)

ø1/2" (12.7mm)

1-5/8" (41.2mm)

BACKSET 2-3/4" (70mm)